

## **Forsmark site investigation**

# **Geophysical, radar and BIPS logging in boreholes HFM06, HFM07 and HFM08**

Per Nilsson, Jaana Aaltonen  
Malå Geoscience AB / RAYCON

March 2003

**Svensk Kärnbränslehantering AB**

Swedish Nuclear Fuel  
and Waste Management Co  
Box 5864  
SE-102 40 Stockholm Sweden  
Tel 08-459 84 00  
+46 8 459 84 00  
Fax 08-661 57 19  
+46 8 661 57 19



## **Forsmark site investigation**

# **Geophysical, radar and BIPS logging in boreholes HFM06, HFM07 and HFM08**

Per Nilsson, Jaana Aaltonen  
Malå Geoscience AB / RAYCON

March 2003

*Keywords:* BIPS, RAMAC, Wellmac, radar, TV, geophysical logging.

This report concerns a study which was conducted for SKB. The conclusions and viewpoints presented in the report are those of the authors and do not necessarily coincide with those of the client.

A pdf version of this document can be downloaded from [www.skb.se](http://www.skb.se)

# Contents

<b>1</b>	<b>Introduction</b>	5
<b>2</b>	<b>Objective and scope</b>	6
<b>3</b>	<b>Equipment</b>	7
3.1	Wellmac	7
3.1.1	Description of the Wellmac system	7
3.1.2	Temperature and fluid resistivity	9
3.1.3	Caliper measurements	9
3.1.4	Electrical methods	9
3.1.5	Magnetic methods (SUS)	11
3.1.6	Natural gamma	11
3.1.7	Density	12
3.2	RAMAC	12
3.3	TV-Camera, BIPS	13
<b>4</b>	<b>Execution</b>	15
4.1	Data acquisition	15
4.2	Analyses and interpretation	19
<b>5</b>	<b>Results and data delivery</b>	23
5.1	Geophysical logging with Wellmac	23
5.2	RAMAC logging	23
5.3	BIPS logging	26
<b>6</b>	<b>References</b>	27
	<b>Appendix 1</b> Geophysical logging, Wellmac	29
	<b>Appendix 2</b> Radar logging dipole antennas 20, 100 and 250 MHz	41

# 1 Introduction

This document reports the data gained during logging operations, which is one of the activities performed within the site investigation at Forsmark. The logging operations presented here include geophysical logging with Wellmac, RAMAC and BIPS. In total, 366 metres of logging was carried out in three percussion drilled boreholes. The boreholes in question are; HFM06 (c 106 m / diameter 140 mm), HFM07 (c 120 m / 140 mm) and HFM08 (c 140 m / 140 mm). The location of the boreholes is shown in Figure 1-1.

All measurements were conducted by RAYCON during December 2002. The work was carried out according to activity plan AP PF 400-02-43 (SKB internal controlling document).

Instruments used:

- Borehole radar (RAMAC) system with dipole radar antennas.
- Borehole TV system (Borehole Image Processing System – BIPS), a high resolution, side viewing, colour borehole TV system.
- Borehole geophysical logging system (WELLMAC).

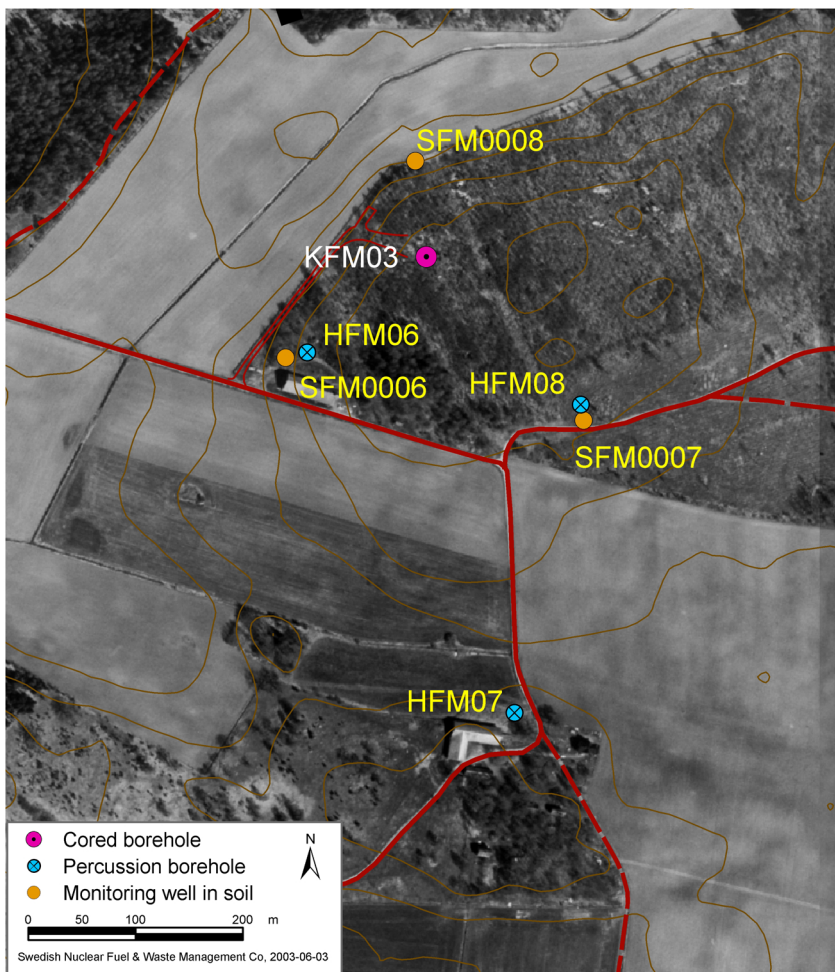

*Figure 1-1. Overview of drillsite No 3 in the Forsmark area.*

## **2 Objective and scope**

The objective of the survey is to both receive information on the borehole itself and from the rock mass around the borehole. Borehole radar was used to investigate the nature and the structure of the rock mass located around the boreholes and BIPS for geological surveying and fracture mapping and orientation. Geophysical logging was used to measure changes in physical properties in the borehole fluid and the bedrock surrounding the boreholes.

This report describes the equipment used as well as the measurement procedures and results. For the BIPS survey, the results are presented as images. Radar data is presented in radargrams and identified reflectors in each borehole are listed in tables. Geophysical logging data is presented in graphs as a function of depth.

## **3 Equipment**

### **3.1 Wellmac**

The following physical parameters have been investigated:

- Fluid resistivity
- Temperature
- Caliper
- Normal resistivity
- Lateral resistivity
- Single point resistance
- Magnetic susceptibility
- Natural gamma ray
- Density

#### **3.1.1 Description of the Wellmac system**

Malå Geoscience, Sweden, produces the WELLMAC Logging System used within this study. The geophysical logging system includes five major parts; a measuring probe suite, a power supply/modem probe, a surface unit with software, a cable drum or winch and a depth-measuring wheel, see Figure 3-1.

Each probe can be used individually or assembled with up to six others to form a probe suite. The power supply/modem probe (controller probe), which is always mounted on top of the probe suite, serves to take care of the power supply to the probes and the data communication between the surface unit and the probes.

#### ***Surface equipment***

The surface unit used for probe control and data acquisition is based on an IBM-AT compatible computer. It is water tight and designed for use in harsh environments. Log data from the probes is continuously displayed on the screen while measuring proceeds. Data is stored on a hard drive and/or floppy disks. Moreover, data can be printed out in real time on a printer connected to the surface unit. During this project, a laptop computer was used instead of the surface unit.

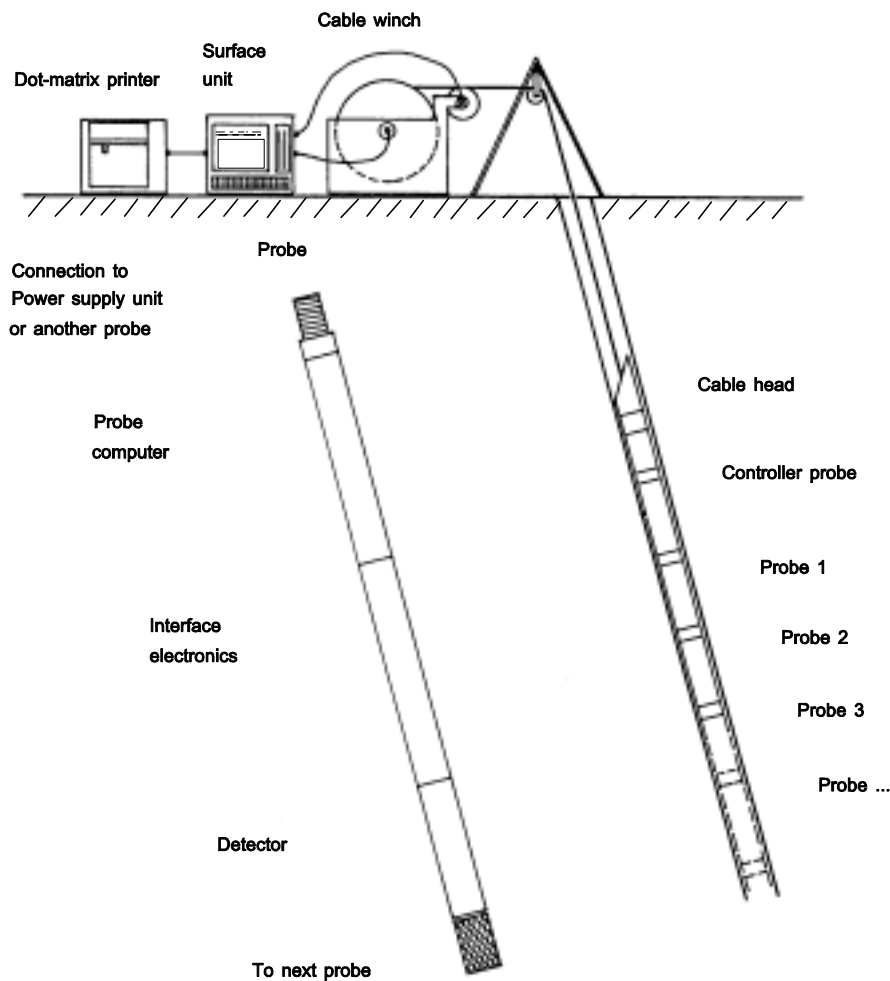

**Figure 3-1.** *The Wellmac system.*

The surface equipment consists of the following parts:

- Computer.
- Measuring wheel with digital counter.
- Winch with cable.
- Power supply (generator) or 220 V.

The motor-driven winch used in this study is electrically powered by a portable generator or, when available, by 220 AC power.

The depth-measuring wheel, which also serves as a pulley, has a 1-metre circumference and is mounted on a tripod. The depth-measuring device is an odometer, which transmits data to the surface unit.

### **3.1.2 Temperature and fluid resistivity**

The temperature and resistivity of the borehole fluid are measured simultaneously using the same probe. The best accuracy and resolution are obtained when measuring discrete points, but it is also possible to measure continuously. In this investigation, both the temperature and the fluid resistivity were measured continuously.

#### ***Temperature***

The temperature is measured with a thermistor and the results are expressed in °C. When measuring discrete points, the absolute accuracy is 0.06°C and the relative accuracy 0.004°C. When measuring continuously these values are 0.1°C and 0.05°C respectively. Calibration is made in the laboratory using a quartz thermometer.

#### ***Fluid resistivity***

The resistivity of the borehole fluid is measured by a five-electrode system. The electrodes are positioned in a plastic tube, open at both ends. The insulation from the formation is necessary to eliminate the effect of conducting minerals and fractures in the surrounding rock formation.

Calibration is performed in the laboratory where the probe is lowered into water with a known salinity. The procedure is repeated for different water salinities.

The results are expressed in ohmmetres and can, after correction for the temperature, be used to calculate the salinity of the drillhole fluid. The results can also be used for corrections of the data obtained from the electric measurements.

### **3.1.3 Caliper measurements**

The borehole diameter is measured continuously along the borehole by means of a three-arm caliper connected to the main surface unit. The caliper measures the diameter using three motor-actuated spring loaded arms. The caliper can be closed and opened by remote control and includes different sets of caliper arms to obtain the highest possible accuracy depending on actual borehole diameter.

Calibration of the caliper tool is carried out by placing the probe into jigs of known diameters. At the site, calibration was also performed running the tool in the casing.

### **3.1.4 Electrical methods**

All electrical methods are based on the ability of minerals and rock to conduct electricity. Electrical methods cannot be run in empty boreholes, boreholes with non-conductive mud or boreholes with casing, since the electrodes of the probes need to be in electrical contact with the surrounding rock formation.



Electrical methods are used to measure electrical resistance in the bedrock surrounding the borehole, and the natural potential in the rock. These methods, introduced by Schlumberger in 1928, were the first geophysical techniques used in well logging.

The resistivity probe used in this project is able to measure five electrical parameters at the same time. These are; short normal, long normal and lateral resistivity, single point resistance and spontaneous potential. The major difference between the various electrical methods, except spontaneous potential and single point resistance, is the electrode configuration.

## ***SP***

Self-potential or spontaneous potential (SP) is usually taken as the measured voltage of a downhole electrode relative to a surface electrode.

Self-potential variations in a borehole may arise from the diffusion of ions either from the borehole fluid into the formation or the reverse, and from oxidation-reduction reactions of minerals in the vicinity of the borehole.

## ***Single point resistance (SPR)***

The single point resistance method consists of a two-electrode system with one of the electrodes positioned in the borehole and the other at the surface. The small electrode (length 2 cm) in the borehole is surrounded by an insulator slightly smaller than the diameter of the borehole to reduce the effect of electrically conductive groundwater in the borehole. The resistance may be measured at any of four different frequencies; 3, 11, 33 or 110 Hz. The frequency used in this investigation was 11 Hz.

The results are calibrated, and if necessary also corrected for the borehole dimension, and expressed in ohm.

## ***Normal resistivity***

The resistivity of the bedrock is determined by means of a four-electrode system. In the normal configuration, one current and one potential electrode are located in the borehole. The distance between the active electrodes in the borehole is 1.6 and 0.4 m, respectively. The other two electrodes are placed at the surface approximately 50 m from the borehole in opposite directions. Two different normal configurations were used in this investigation. Data presented and delivered is from the 0.4 m configurations.

Calibration of the resistivity system is done at the site by connecting a variable resistor to the system, thus calibrating the response to a known resistance. The results are expressed in ohmmetres.

### ***Lateral resistivity***

The lateral configuration has one current electrode and two potential electrodes in the borehole, while the other current electrode is on the surface. The distance between the current electrode and the first potential electrode is 1.6 m and the distance between the potential electrodes is 0.1 m. This configuration has a radius of investigation that is approximately equal to the distance between the middle point of the two potential electrodes and the current electrode. The major advantage of the lateral configuration compared to the normal configuration is its ability to detect thin layers. However, the true resistivity of a layer will be read only if it is much thicker than the radius of investigation.

### **3.1.5 Magnetic methods (SUS)**

This probe is used to determine the magnetic susceptibility of the bedrock. Magnetic susceptibility is defined as the ratio of the intensity of magnetization of a magnetizable substance to the intensity of an applied magnetic field. The magnetic susceptibility of a rock depends on its content of ferromagnetic minerals, such as magnetite, titanomagnetite, ilmenite and pyrrhotite. Changes in the concentrations of ferromagnetic minerals usually coincide with lithological changes in the bedrock. The susceptibility probe can also be used for the location of fracture zones, due to oxidation of magnetite to hematite in these zones.

The magnetic susceptibility sensor consists of a solenoid, wound on a high permeability core and connected to an electrical bridge. The presence of ferromagnetic minerals in the rock causes variations in the magnetic field that affect the amount of electric current in the coil. These variations are measured with the electrical bridge circuit, and translated into calibrated magnetic susceptibility units.

The instrument has three measuring ranges, viz.  $0-2 \times 10^{-2}$ ,  $0-2 \times 10^{-1}$  and  $0-2$  SI units, and the resolution is  $5 \times 10^{-5}$  SI units. Calibration is done by means of calibration pads with known magnetic susceptibility.

### **3.1.6 Natural gamma**

This probe measures the natural gamma radiation in the borehole. The radiation is due to the decomposition of radioactive isotopes. The most significant contribution to the radiation is given by isotopes of K, U and Th, and the concentration of these elements usually reflects the bedrock lithology. Generally, high values of radiation correspond to acid rocks and low values to mafic rocks. Logging gamma radiation is also a good method for locating alteration zones.

The probe contains a scintillation detector. The active part is a 1.5 inch crystal of NaI, which is connected to a photomultiplier tube that transforms the light pulses created in the crystal to electrical signals proportional to the incoming gamma rays. The lower cut-off limit in gamma ray energy is 300 KeV.

Calibration is made by means of a well-known radioactive source. After calibration, the results can be presented in micro-Roentgen/hour.

### **3.1.7 Density**

The density or gamma-gamma probe measures rock density and is used mainly for lithological characterization. Further, if the matrix density is known, the porosity of the rock can be determined. This, in turn, leads to the possibility of locating fracture zones.

The density probe is in principle a gamma probe with a shielded radioactive source, in this case is 300 mCi Cesium-137 source, which emits gamma rays at 662 keV. The emitted gamma rays penetrate the rock formation, where they gradually lose energy through interaction with nuclei in the rock, until they are either entirely absorbed by the rock matrix or reach the detector. Formations with a high density absorb the gamma radiation more effectively than low density formations.

Three kinds of interaction between gamma rays and matter may affect the detector response: Compton scattering, photoelectric absorption and pair production. However, the probability of a specific gamma ray interaction occurring will depend on the energy of the gamma ray. The photoelectric effect is the dominating process for energies below 100 keV, while pair production occurs if the gamma ray energy is above the threshold value of 1022 keV. At the energy level of the radioactive source used in the density probe, the dominating process is Compton scattering.

Calibration of the density probe is made on a regular basis at a site in Malå. The calibration site consists of a number of boreholes with different diameters and formation densities.

## **3.2 RAMAC**

The RAMAC GPR system owned by SKB is a fully digital GPR system, where emphasis has been laid on fast survey speed and easy field operation. The system operates dipole and directional antennas (see Figure 3-2). A system description is given in “Metodbeskrivning för borrhålsradar” (SKB MD 252.020, ver 1.0) and references therein.

The borehole-radar system consists of a transmitter and a receiver. An electromagnetic pulse, within the frequency range of 20 to 250 MHz, is emitted and penetrates the bedrock. When a feature, e.g. a water-filled fracture, with different electrical properties is encountered, the pulse is reflected back to the receiver.

Low antenna frequency gives less resolution but higher penetration rate compared to a higher frequency.

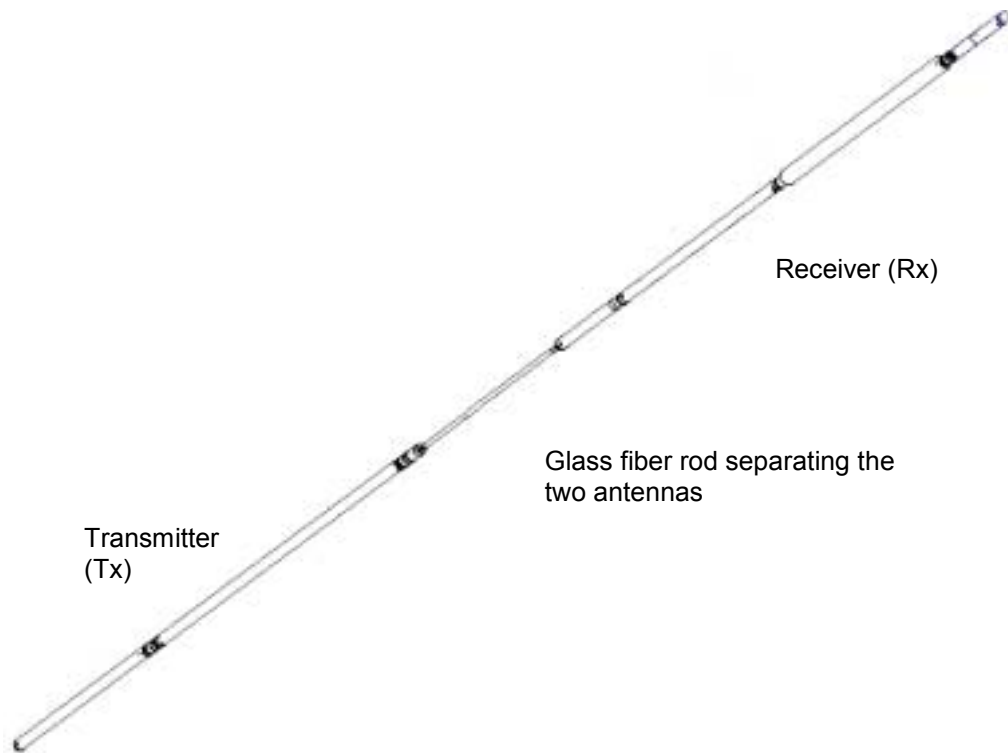
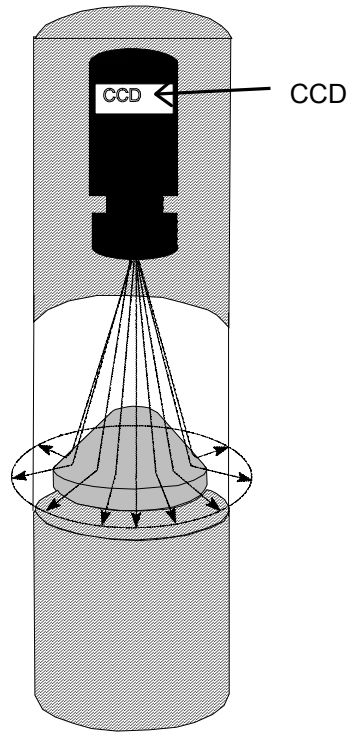

*Figure 3-2. Example of a borehole antenna.*

### **3.3 TV-Camera, BIPS**

The BIPS 1500 system used is owned by SKB and described in “Metodbeskrivning för TV-loggning med BIPS” (SKB MD 222.006, ver 1.0). The BIPS method for borehole logging produces a digital scan of the borehole wall. In principle, a standard CCD video camera is mounted in a probe in front of a conical mirror (see Figure 3-3). An acrylic window covers the mirror part and the borehole image is reflected through the window and displayed on the cone, from where it is recorded. During the measuring operation, pixel circles are scanned with a resolution of 360 pixels/circle. The digital pixel circle is then stored for every 1 millimetre on a MO-disk in the surface unit.

There are two ways to orientate the images, either with a compass or with a gravity sensor. The compass is used for vertical boreholes and the gravity sensor for inclined boreholes.



*Figure 3-3. The conical mirror scanning for the BIPS system.*

## 4 Execution

### 4.1 Data acquisition

#### *Wellmac logging*

To allow for the best possible depth control of the individual runs, the Gamma probe was attached to the tool string for all individual runs. Five rounds of measurements were performed in every borehole. First, the Gamma and Temp/Fluid resistivity probes were used and afterwards the remaining probes were employed.

For the geophysical logging, the following combinations were applied:

1. Gamma/Temp/Fluid resistivity
2. Gamma/Caliper
3. Gamma/Susceptibility
4. Gamma/Lateral/Normal/SPR
5. Gamma/Density

Measurements were made during continuous movement of the probes at a depth interval of 0.1 metre. Data from the measurements was recorded on a field PC.

For further information, see “Metodbeskrivning för geofysisk borrhålsloggning” (SKB MD 221.002, ver 1.0) and “Instruktion för rengöring av borrhålsutrustning” (SKB MD 600.004, ver 1.0) for cleaning of equipment.

To obtain a good quality of the density recordings, two boreholes with a diameter of 140 mm were drilled in boulders which were sampled for density determination in the laboratory. Analyses of the samples are presented in Table 4-1. The final results of the logging are presented in the standard density unit,  $\text{kg/m}^3$ .

**Table 4-1. Results from parameter measurements of samples from surface boulders.**

Sample	$\text{kg/m}^3$
SKBA1	2993
SKBA2	2997
SKBA3	2990
SKBB1	2646
SKBB2	2637
SKBB3	2645
SKBB4	2629

The final data is delivered on ASCII format, depth vs. logged parameter, of every single method.

## **RAMAC**

For the borehole radar measurements, dipole antennas were used. The antennas have a central frequency of 20 MHz, 100 MHz and 250 MHz respectively.

During logging, the antennas (transmitter and receiver) were lowered continuously in the borehole and the data recorded on the field PC along the measured interval. The antennas are kept at a fixed separation by glass fiber rods (Figure 3-2). See also Figure 4-1.

For information on system settings for the different antennas used in the investigation of HFM06, HFM07 and HFM08, see Table 4-2 – Table 4-4 below.

For further information, see SKB MD 252.020 (ver 1.0) for method description and MD 600.004 (ver 1.0) for cleaning of equipment.

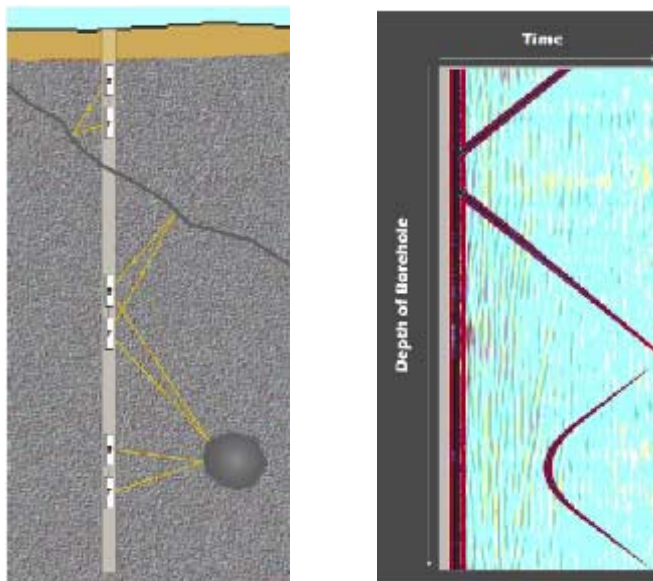

**Figure 4-1.** The principle of borehole radar reflection surveys (left) and resulting radargram (right).

**Table 4-2. Radar logging information from HFM06.**

<b>Site:</b>		<b>Logging company:</b>				
<b>BH:</b>	<b>Forsmark</b>	<b>RAYCON</b>				
<b>Type:</b>	<b>KFM06</b>	<b>Equipment:</b>	<b>SKB RAMAC</b>			
<b>Operator:</b>	<b>Dipole</b>	<b>Manufacturer:</b>	<b>MALÅ GeoScience</b>			
	<b>CG</b>	<b>Antenna</b>				
		<b>250 MHz</b>	<b>100 MHz</b>	<b>20 MHz</b>		
Logging date:		03-02-25	03-02-25	03-02-25		
Reference:		T.O.C.	T.O.C.	T.O.C.		
Sampling frequency (MHz):		2588	951	247		
Number of samples:		619	518	512		
Number of stacks:		Auto	Auto	Auto		
Signal position:		-0.32	-0.32	-1.36		
Logging from (m):		1.5	2.6	6.25		
Logging to (m):		107.4	106.7	102.3		
Trace interval (m):		0.1	0.2	0.25		
Antenna separation (m):		2.4	3.9	10.05		

**Table 4-3. Radar logging information from HFM07.**

<b>Site:</b>		<b>Logging company:</b>				
<b>BH:</b>	<b>Forsmark</b>	<b>RAYCON</b>				
<b>Type:</b>	<b>HFM07</b>	<b>Equipment:</b>	<b>SKB RAMAC</b>			
<b>Operators:</b>	<b>Dipole</b>	<b>Manufacturer:</b>	<b>MALÅ GeoScience</b>			
	<b>CG</b>	<b>Antenna</b>				
		<b>250 MHz</b>	<b>100 MHz</b>	<b>20 MHz</b>		
Logging date:		03-02-12	03-02-12	03-02-12		
Reference:		T.O.C.	T.O.C.	T.O.C.		
Sampling frequency (MHz):		2588	951	247		
Number of samples:		619	518	512		
Number of stacks:		Auto	Auto	Auto		
Signal position:		-0.32	-0.32	-1.36		
Logging from (m):		1.5	2.6	6.25		
Logging to (m):		120	119.3	115.4		
Trace interval (m):		0.1	0.2	0.25		
Antenna separation (m):		2.4	3.9	10.05		



**Table 4-4. Radar logging information from HFM08.**

			250 MHz	100 MHz	20 MHz
Site:	Forsmark	Logging company:	RAYCON		
BH:	HFM08	Equipment:	SKB RAMAC		
Type:	Dipole	Manufacturer:	MALÅ GeoScience		
Operators:	CG	Antenna			
Logging date:			03-02-26	03-02-26	03-02-26
Reference:			T.O.C.	T.O.C.	T.O.C.
Sampling frequency (MHz):			2588	951	247
Number of samples:			619	518	512
Number of stacks:			Auto	Auto	Auto
Signal position:			-0.33	-0.32	-1.36
Logging from (m):			1.5	2.6	6.25
Logging to (m):			141.2	141.2	136.3
Trace interval (m):			0.1	0.2	0.25
Antenna separation (m):			2.4	3.9	10.05

There are several ways to determine the radar wave propagation velocity, each of them having both advantages and disadvantages. In this project, the velocity determination was performed by keeping the transmitter fixed in a borehole while moving the receiver downwards in the same borehole. The result is plotted in Figure 4-2 and the calculation shows a velocity of 128 m/micro seconds. The velocity measurement was performed, within another project /1/, in borehole HFM03 with the 100 MHz antenna.

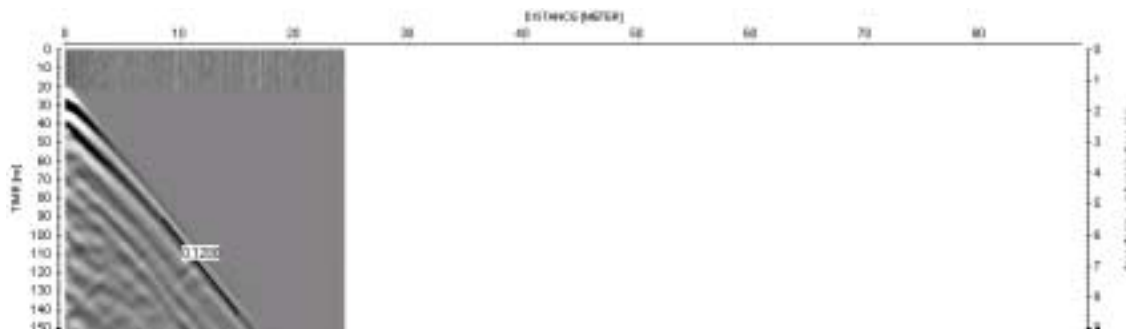

**Figure 4-2. Results from velocity measurements in HFM03 /1/.**

## ***BIPS***

For information on BIPS measurements, see SKB MD 222.006 (ver 1.0) for a method description and MD 600.004 (ver 1.0) for cleaning of equipment.

The measurements were performed according to the method description. A pixel circle with a resolution of 360 pixels/circle was used and the digital pixel circles were then stored for every 1 millimetre on a MO-disc in the surface unit, giving a maximum logging speed of 1.5 metre/minute. In this project, a gravity sensor was used to measure the orientation of the BIPS images.

In percussion drilled boreholes, there are no traces on the borehole walls or any other simple means to be used for calibration of the length measuring devices. Therefore, no depth adjustment was performed on the delivered data. To control the quality of the system, a calibration measurement was performed in a test pipe before start of the logging of the first borehole and after finishing the last logging. The results showed no difference in colours and focus of the images. Results of the test loggings were included in the delivery of the data in bip-format and pdf-format.

## **4.2 Analyses and interpretation**

### ***Wellmac logging***

The individual runs are adjusted for errors of depth recordings based on the gamma measurements. No correlation based on other information related to the drilling or other positioning has been adopted to the results.

The data processing includes calibration versus calibration tables and adjustment for drift, if necessary (e.g. temperature drift). Statistical noise filtering is not carried out on the data delivered to SKB.

The visualization of data (Appendix 1) is made with WellCad; a Windows based processing software for filtering, presentation and analyses of geophysical logging data.

### ***RAMAC***

The results from radar measurements are most often presented in the form of radargrams where the position of the probe is shown along one axis and the propagation along the other. The amplitude of the received signal is represented by a grey scale where dark colour corresponds to the large positive signals and light colour to large negative signals. Grey colour corresponds to no reflected signals.

The data presented in this report is related to the measurement point of the antennas, which is defined to be the central point between the transmitter and the receiver antenna.

The two basic patterns to interpret in borehole measurements are point and plane reflectors. In the reflection mode, the borehole radar essentially gives a high-resolution image of the rock mass, showing the geometry of plane structures (contacts between

layers, thin marker beds, and fractures), which may or may not intersect the borehole, or indicating the presence of local features (cavities, lenses etc) around the borehole.

The distance to a reflecting object or plane is determined by measuring the difference in arrival time between the direct and the reflected pulse. The basic assumption is that the speed of propagation is uniform in the entire rock volume. A rock velocity of 128 m/μs is adopted for the interpretations made, as calculated from measurements in borehole HFM03 /1/.

The visualization of data (Appendix 2) is made with REFLEX; a Windows based processing software for filtering and analysis of radar data. The processing steps are shown in Table 4-5 – Table 4-7.

For the interpretation of the intersection angle between the borehole axis and the planes visible on the radargrams, the RadinterSKB software has been used. The interpreted intersection point and intersection angle of the detected structures are presented in the Tables 5-2–5-3 (Section 5.2). The detected structures are also visible on the radargrams in Appendix 2.

**Table 4-5. Processing steps for borehole radar data from HFM06.**

<b>Site:</b>	Forsmark	<b>Logging company:</b>	RAYCON		
<b>BH:</b>	KFM06	<b>Equipment:</b>	SKB RAMAC		
<b>Type:</b>	Dipole	<b>Manufacturer:</b>	MALÅ GeoScience		
<b>Interpret:</b>	JA	<b>Antenna</b>	250 MHz	100 MHz	20 MHz
	□				
	<b>Processing:</b>		DC removal	DC removal	DC removal
			Move start time	Move start time	Move start time
			Gain	Energy decay	Energy decay
				Dewow	Dewow

**Table 4-6. Processing steps for borehole radar data from HFM07.**

<b>Site:</b>	Forsmark	<b>Logging company:</b>	RAYCON		
<b>BH:</b>	HFM07	<b>Equipment:</b>	SKB RAMAC		
<b>Type:</b>	Dipole	<b>Manufacturer:</b>	MALÅ GeoScience		
<b>Interpret:</b>	JA	<b>Antenna</b>	250 MHz	100 MHz	20 MHz
	<b>Processing:</b>		DC removal	□DC removal	DC removal
			Move start time	Move start time	Move start time
			Gain	Gain	Gain

**Table 4-7. Processing steps for borehole radar data from HFM08.**

<b>Site:</b>	<b>Forsmark</b>	<b>Logging company: RAYCON</b>		
<b>BH:</b>	<b>HFM08</b>	<b>Equipment: SKB RAMAC</b>		
<b>Type:</b>	<b>Dipole</b>	<b>Manufacturer: MALÅ GeoScience</b>		
<b>Interpret:</b>	<b>JN</b>	<b>Antenna</b>		
		<b>250 MHz</b>	<b>100 MHz</b>	<b>20 MHz</b>
<b>Processing:</b>		DC removal	DC removal	DC removal
		Move start time	Move start time	Move start time
		Gain	Gain	Gain

***BIPS***

Due to the lack of traces on the borehole walls for calibration of the length measuring devices, no depth adjustment was performed in.

The visualization of data is made with BDPP; a Windows based processing software for filtering, presentation and analyses of BIPS data. No fracture mapping of the BIPS image was performed.

## 5 Results and data delivery

Raw data from the measurements was delivered directly after the termination of the field activities. As regards the BIPS data, this was the final delivery. The geophysical logging data was calibrated and adjusted before the final delivery. RAMAC radar data was interpreted and the result of the interpretation has been delivered.

The delivered data sets have been inserted in the database (SICADA) of SKB. The SICADA reference to the present activity is Field note Forsmark 87.

### 5.1 Geophysical logging with Wellmac

The results from the Wellmac logging are delivered to SKB on a CD. The data on the CD consists of ASCII files for each borehole and method and WellCad files. Moreover, printable pictures in pdf format from WellCad are also delivered on the CD.

The results from the Wellmac logging are presented in Appendix 1. The individual runs are adjusted for recording errors of the depth based on the gamma measurements. On the printouts in Appendix 1, an average filter over 3 measuring points is applied to the gamma and density readings.

Data from the Normal 1.6 logging is not delivered due to poor quality. Normal 1.6 was disqualified because of the bad correlation with the Normal 0.4. This is probably due to the small diameter of the Wellmac probes, as compared to the borehole diameter, in combination with the partly high salinity of the borehole fluid.

### 5.2 RAMAC logging

The results of the interpretation of radar measurements are presented in Tables 5-1–5-4 below and radar data is visualized in Appendix 2. It should be remembered that the images in Appendix 2 are only composite pictures of all events, 360 degrees around the borehole, and do not reflect the orientation of the structures.

Only the larger, clearly visible, structures are interpreted in RadinterSKB. A number of minor structures also exist, as indicated in Appendix 2. It should also be pointed out that reflections interpreted will always have an intersection point with the borehole or the imagined extension of the borehole, but being located further away, they may in some cases not reach the borehole.

The data quality (as seen in Appendix 2) is relatively satisfying, although in some parts of lower quality due to more conductive conditions. A conductive environment makes the radar waves attenuate, which decreases the penetration depth.

Appendix 2 also demonstrates the dependence of the resolution and penetration of radar waves on the antenna frequency. A low frequency offers an increased penetration at the expense of a lower resolution.

The distribution of the identified structures is shown in Table 5-1. As seen in the table, the structures are quite evenly distributed.

**Table 5-1. Distribution of identified structures.**

Distribution of identified structures			
Site:	Forsmark		
Depth	HFM06	HFM07	HFM08
0–50	5	1	3
50–100	3	6	5
100–150	2	1	6
150–200	1		

As demonstrated in Appendix 2, the listed structures can be identified in the data from more than one antenna frequency. Note the negative intersection depth, pointing at structures more or less parallel to the borehole.

**Table 5-2. HFM06, model information from dipole antennas 20, 100 and 250 MHz.**

RADINTER MODEL INFORMATION (20, 100 and 250 MHz Dipole Antennas)			
Site:	Forsmark		
Borehole name:	HFM06		
Nominal velocity (m/μs):	128.0		
Object type	Name	Intersection depth	Intersection angle
PLANE	A	44.1	60
PLANE	AA	-143.1	8
PLANE	B	21.4	59
PLANE	BB	1.4	50
PLANE	C	51.5	55
PLANE	D	70.8	62
PLANE	E	95.8	49
PLANE	EE	111.9	19
PLANE	F	37.4	60
PLANE	G	170.8	15
PLANE	GG	114.8	57

Names in table according to Appendix 2.

**Table 5-3. HFM07, model information from dipole antennas 20, 100 and 250 MHz.**

RADINTER MODEL INFORMATION (20, 100 and 250 MHz Dipole Antennas)			
Site:	Forsmark		
Borehole name:	HFM07		
Nominal velocity (m/ $\mu$ s):	128.0		
Object type	Name	Intersection depth	Intersection angle
PLANE	A	59.7	23
PLANE	AA	2.3	50
PLANE	B	56.5	52
PLANE	BB	-67.6	14
PLANE	C	65.0	48
PLANE	CC	90.8	48
PLANE	D	106.2	49
PLANE	E	76.8	48

Names in table according to Appendix 2.

**Table 5-4. HFM08, model information from dipole antennas 20, 100 and 250 MHz.**

RADINTER MODEL INFORMATION (20, 100 and 250 MHz Dipole Antennas)			
Site:	Forsmark		
Borehole name:	HFM08		
Nominal velocity (m/ $\mu$ s):	128.0		
Object type	Name	Intersection depth	Intersection angle
PLANE	A	31.2	62
PLANE	B	35.4	59
PLANE	C	39.7	62
PLANE	D	50.3	55
PLANE	E	55.2	72
PLANE	EE	64.6	53
PLANE	F	77.7	73
PLANE	G	89.8	56
PLANE	H	115.5	68.5
PLANE	I	128.7	78
PLANE	J	130.9	80
PLANE	K	138.3	81
PLANE	L	124.2	59
PLANE	M	143.6	52

Names in table according to Appendix 2.

### **5.3 BIPS logging**

The results from the BIPS measurements were delivered to SKB before the field crew left the site. This BIPS data delivery was also the final delivery, since no post-processing was to be made.

In order to control the quality of the system, calibration measurements were performed in a test pipe before logging of the first borehole and after logging the last one. The results showed no difference regarding the colours and focus of the images. Results of the test loggings were included in the delivery of the raw data.

The BIPS images show a good quality. Only in the bottom part of the boreholes, the quality is reduced due to dirty borehole fluid.



## 6 References

- /1/ **Gustafsson C, Nilsson P, 2003.** Geophysical, radar and BIPS logging in boreholes HFM01, HFM02, HFM03, and the percussion drilled part of KFM01A. SKB P-03-39. Svensk Kärnbränslehantering AB.

**Geophysical logging, Wellmac**

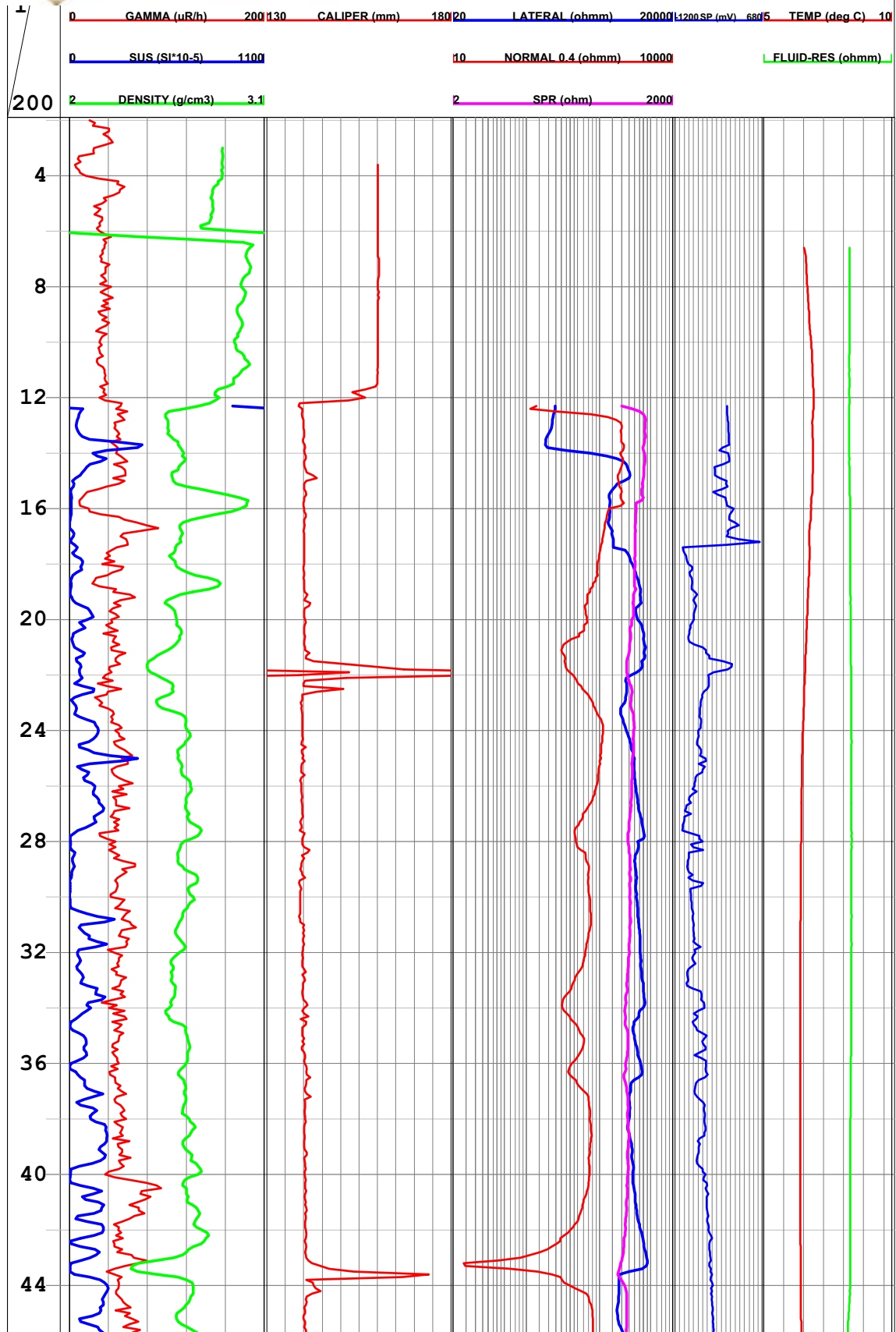

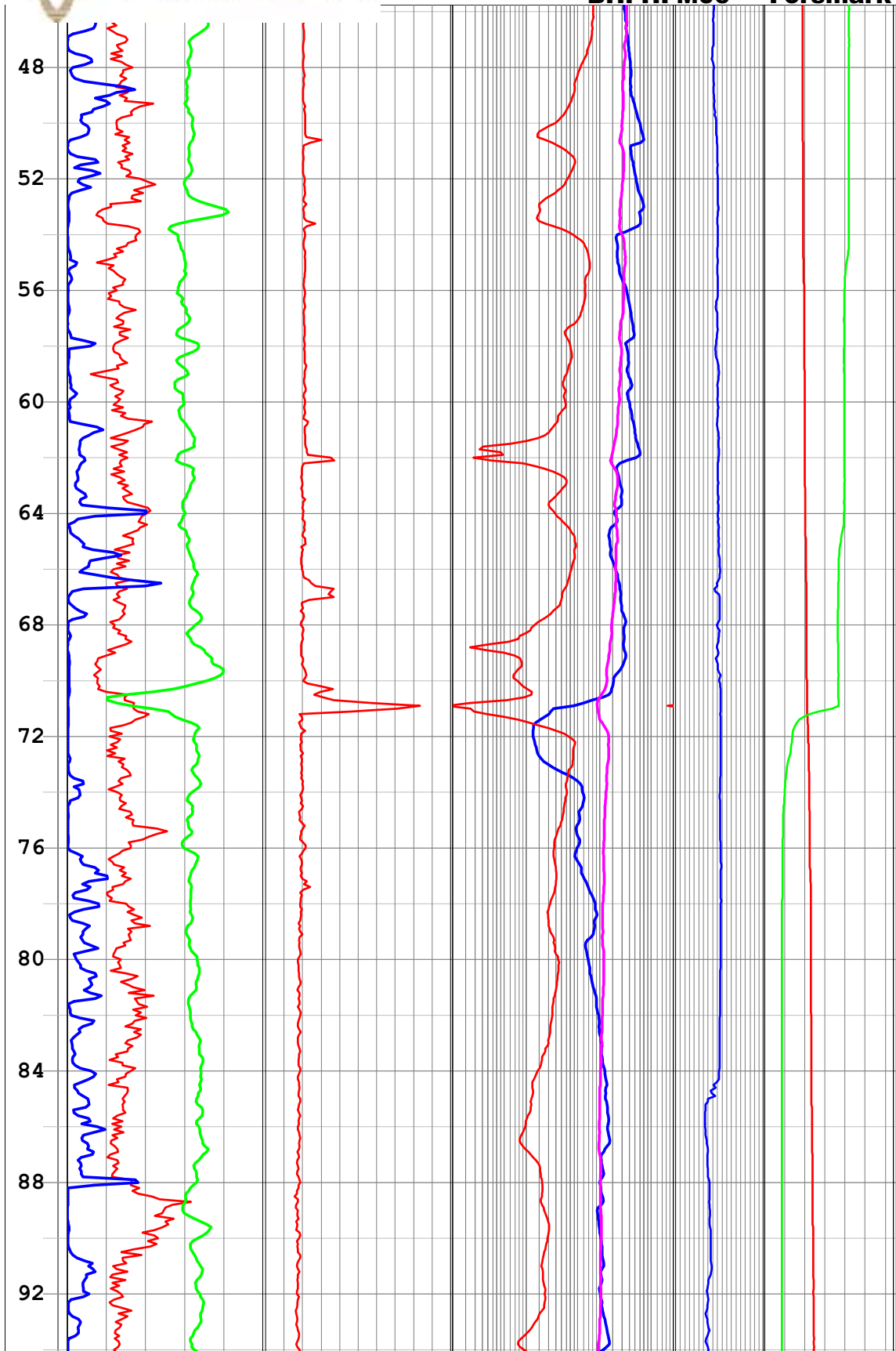

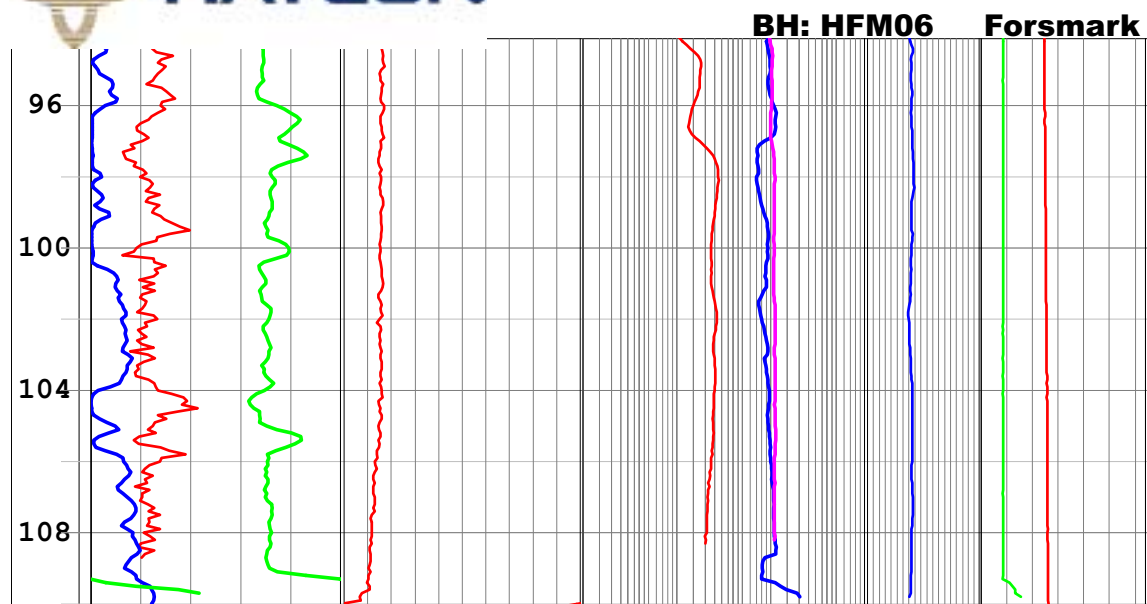



BH: HFM07 Forsmark

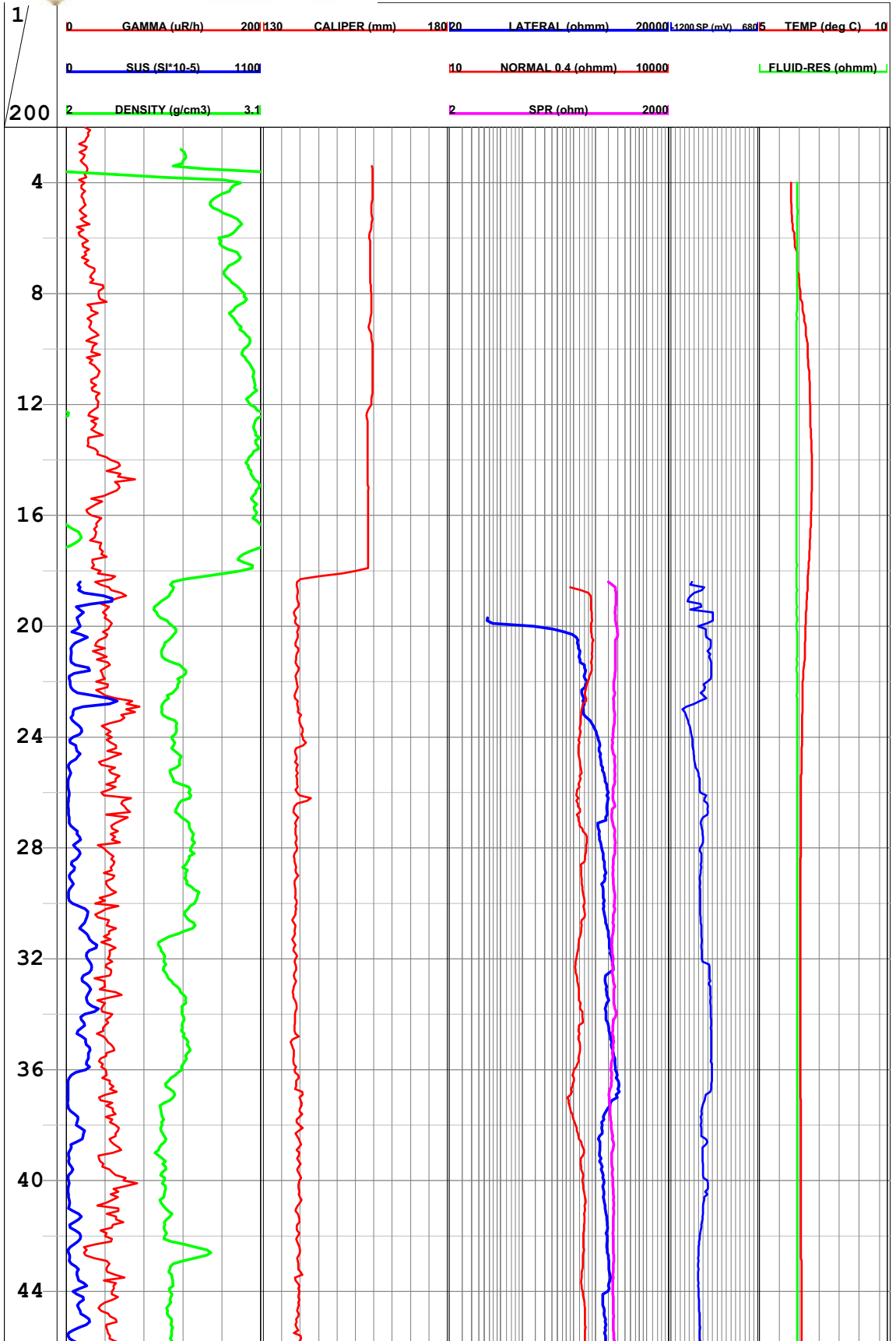



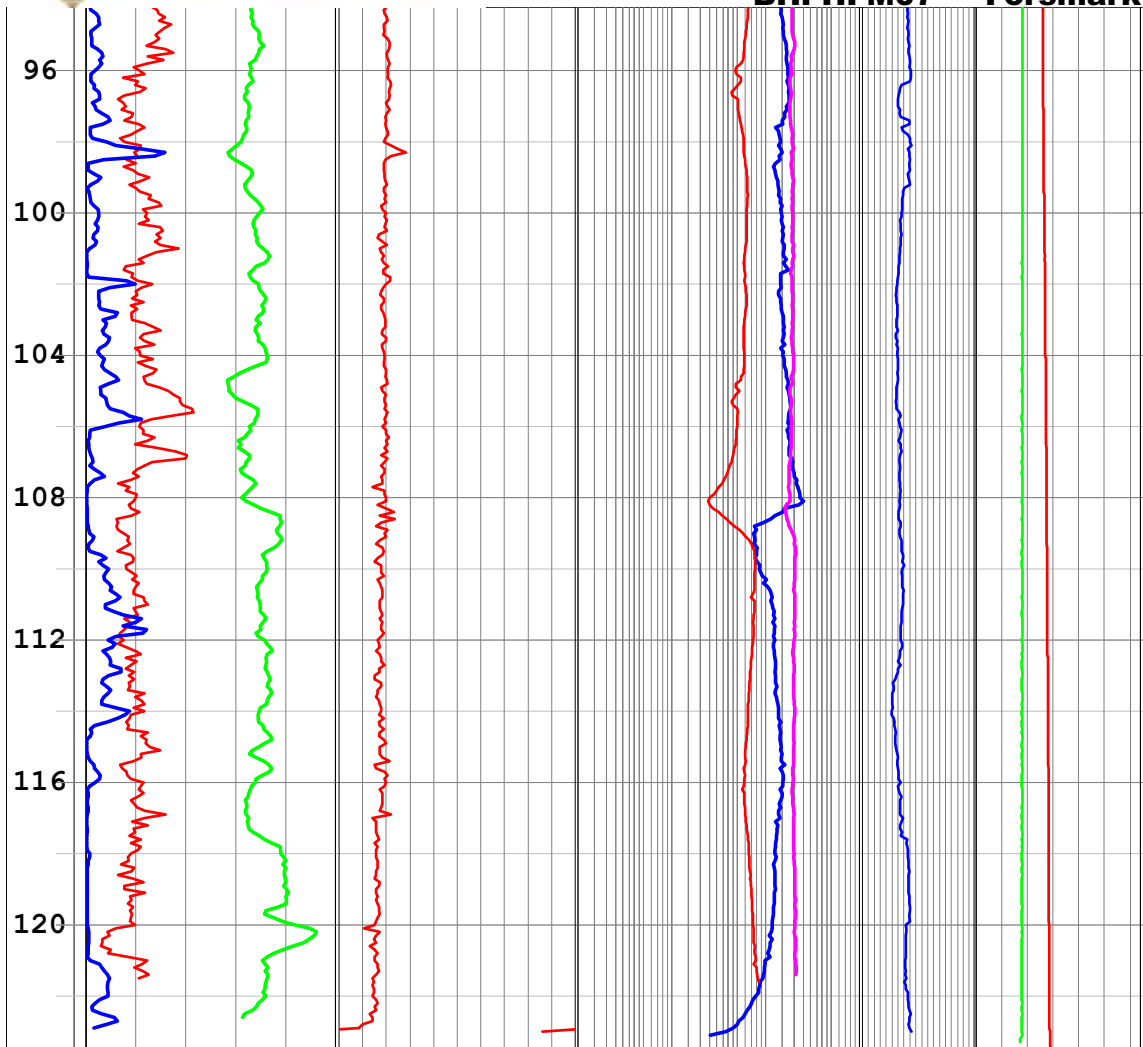





BH: HFM08 Forsmark

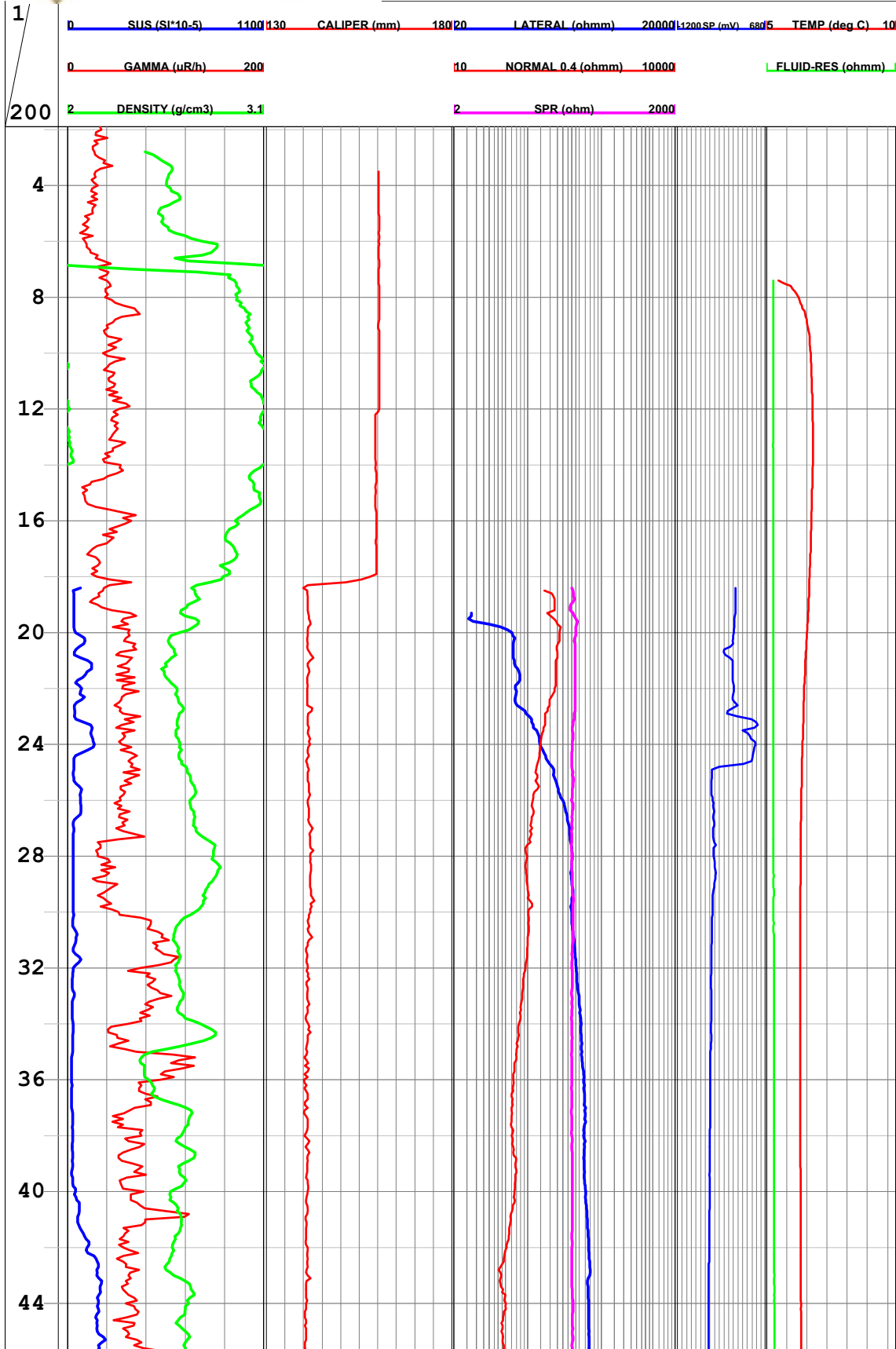

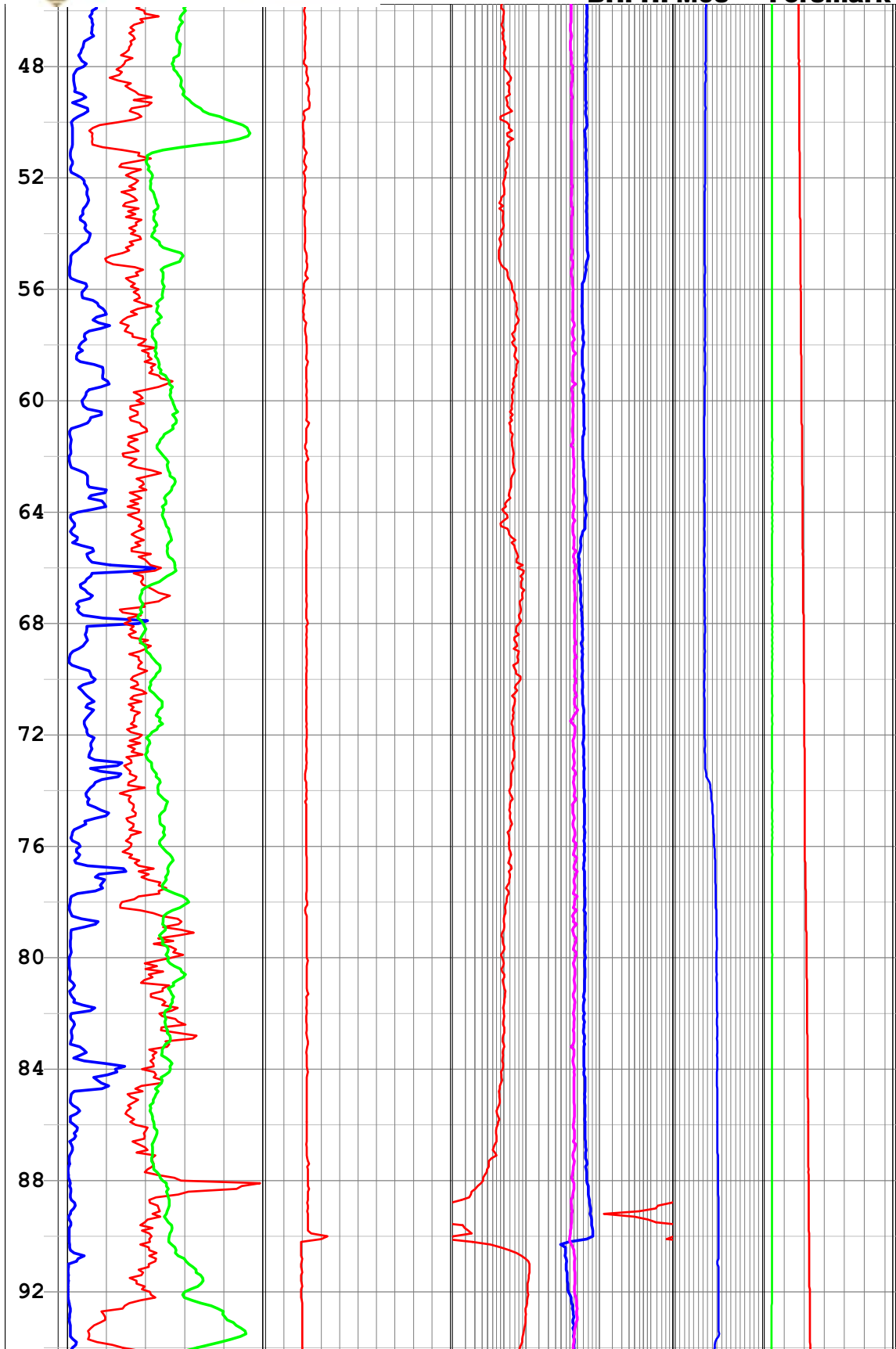

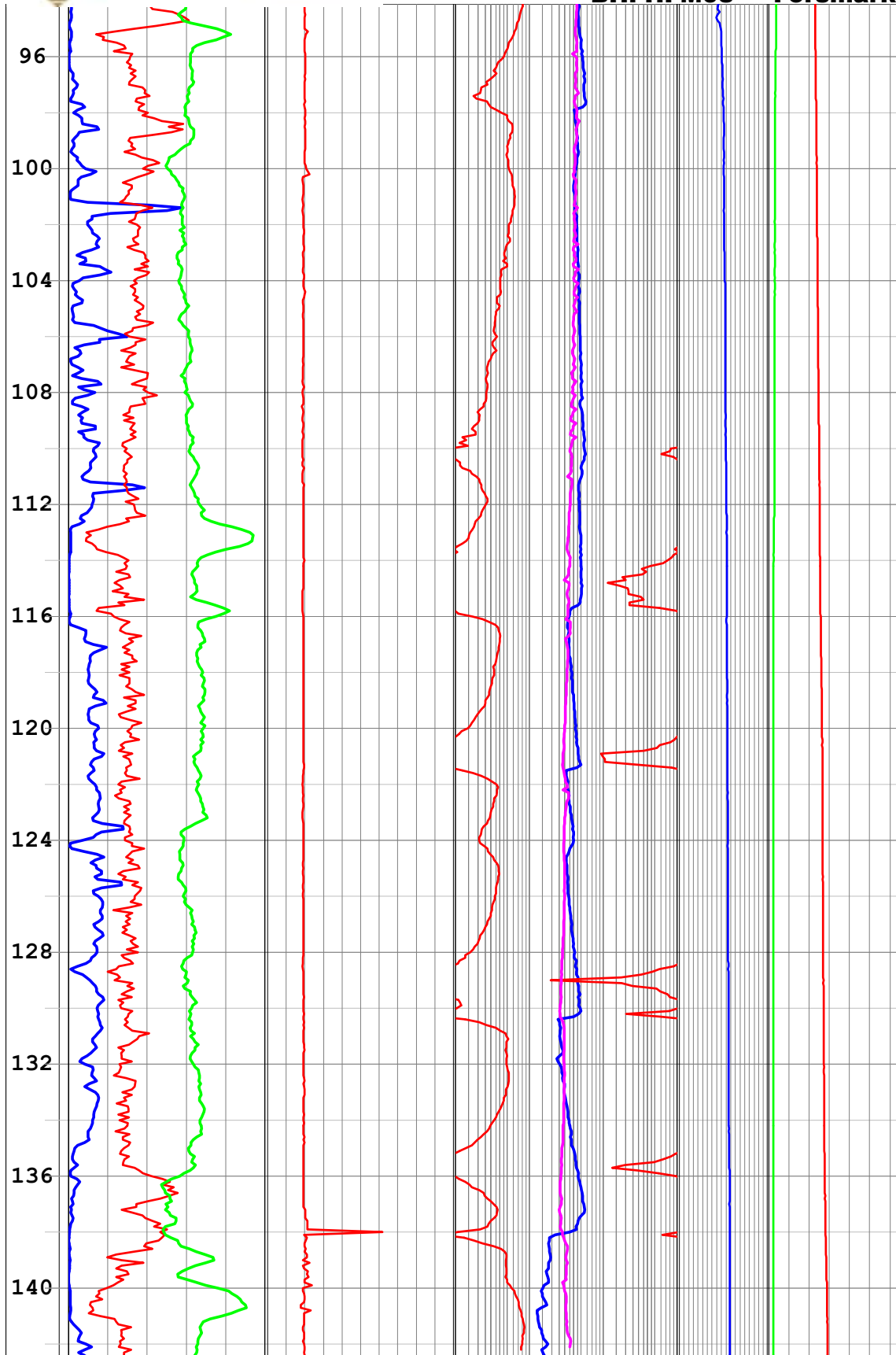



**Radar logging dipole antennas 20, 100 and 250 MHz**

**FORSMARK HFM06 with interpretation**

42

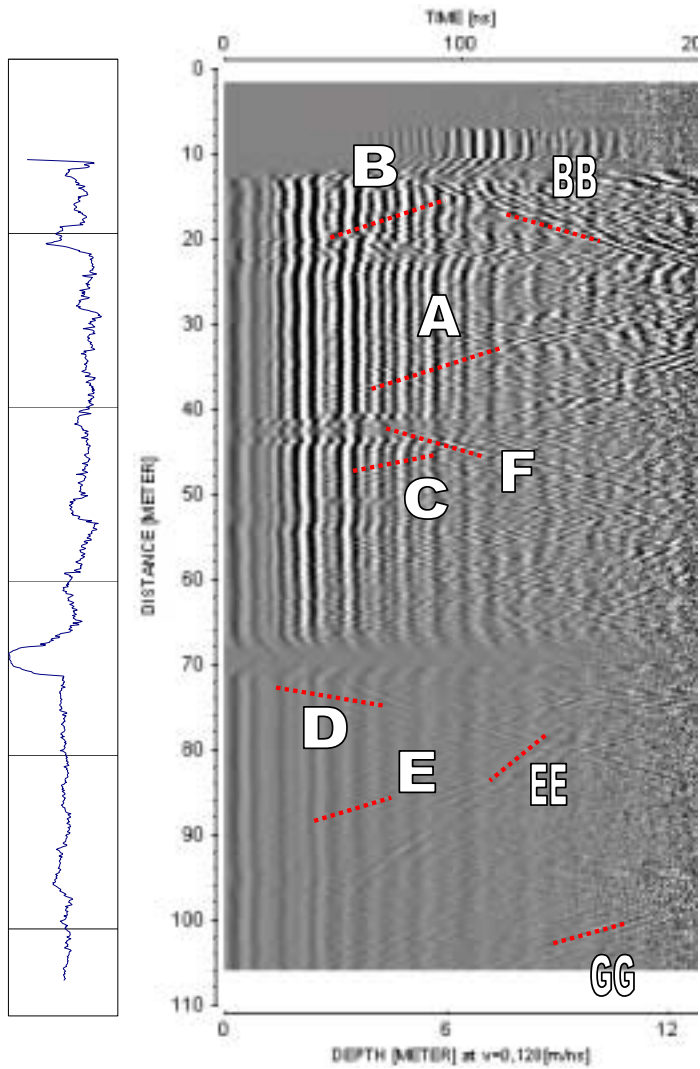

**250 MHz**

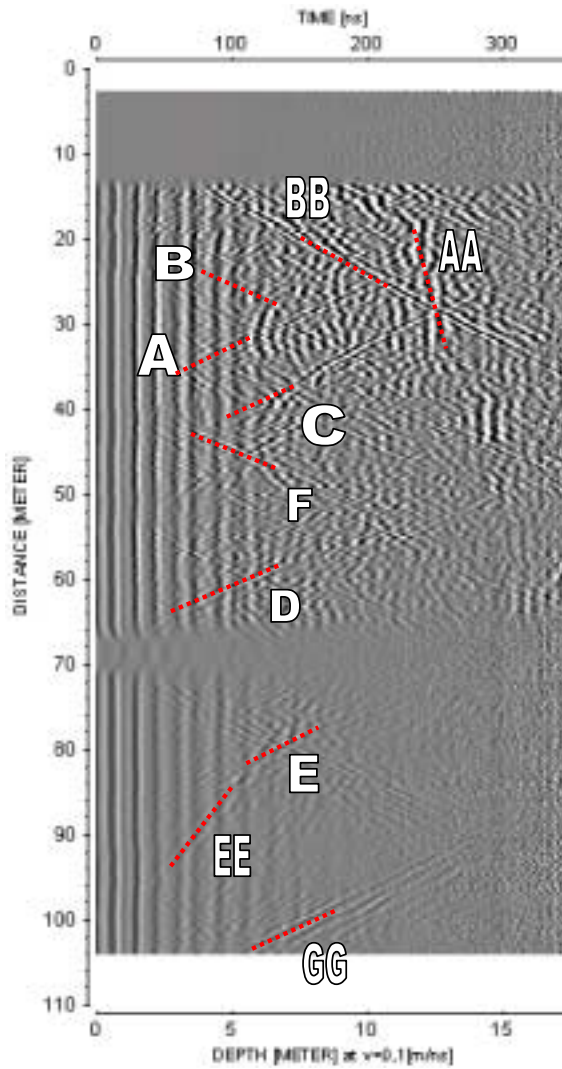

**100 MHz**

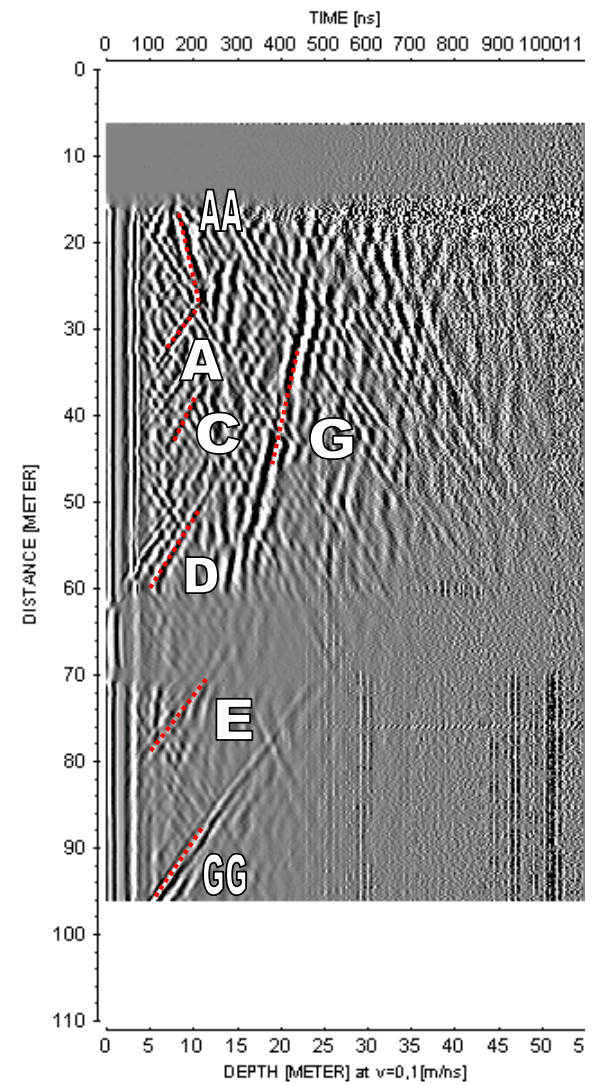

**20 MHz**



**FORSMARK HFM07 with interpretation**

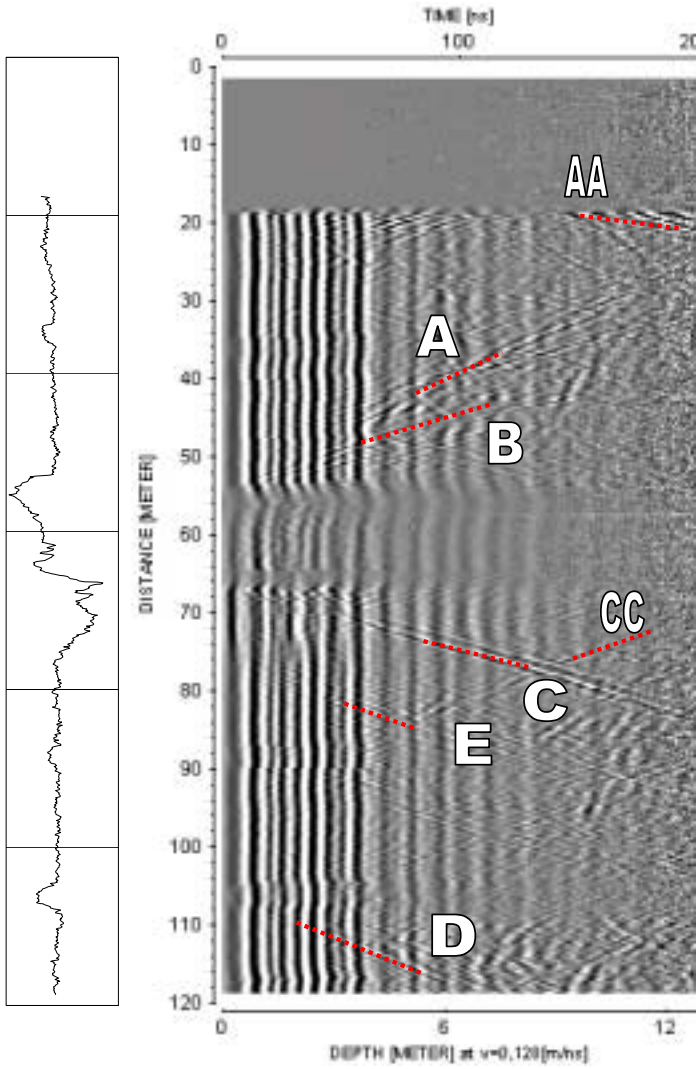

**250 MHz**

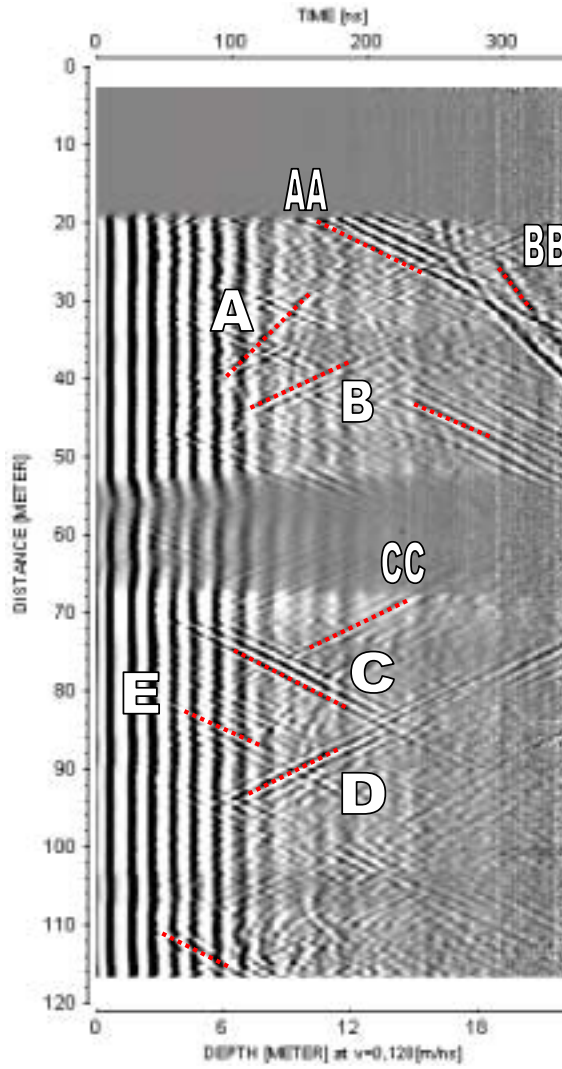

**100 MHz**

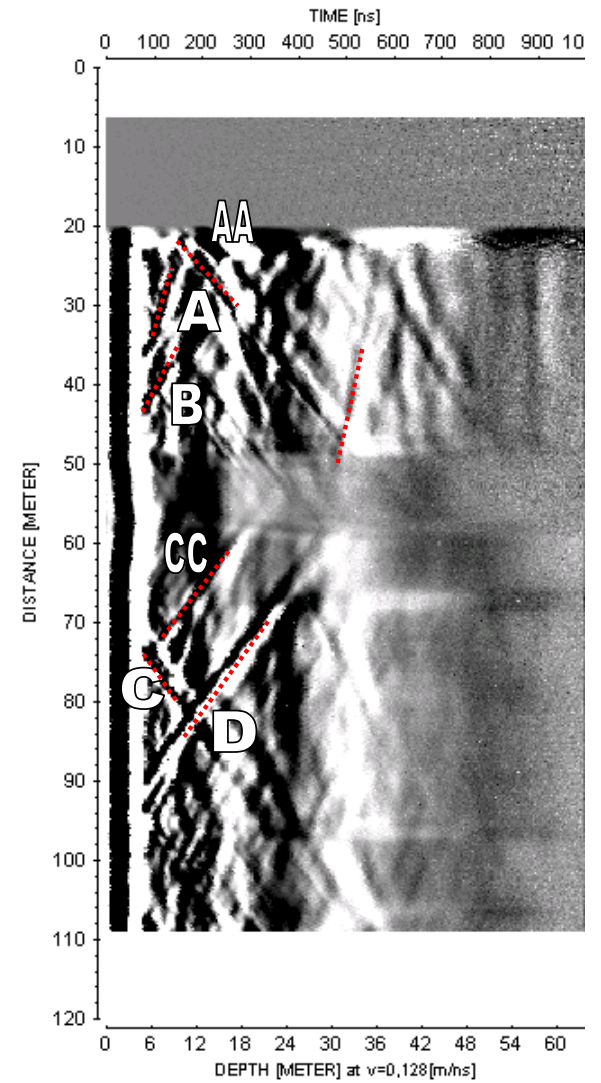

**20 MHz**

Forsmark HFM08

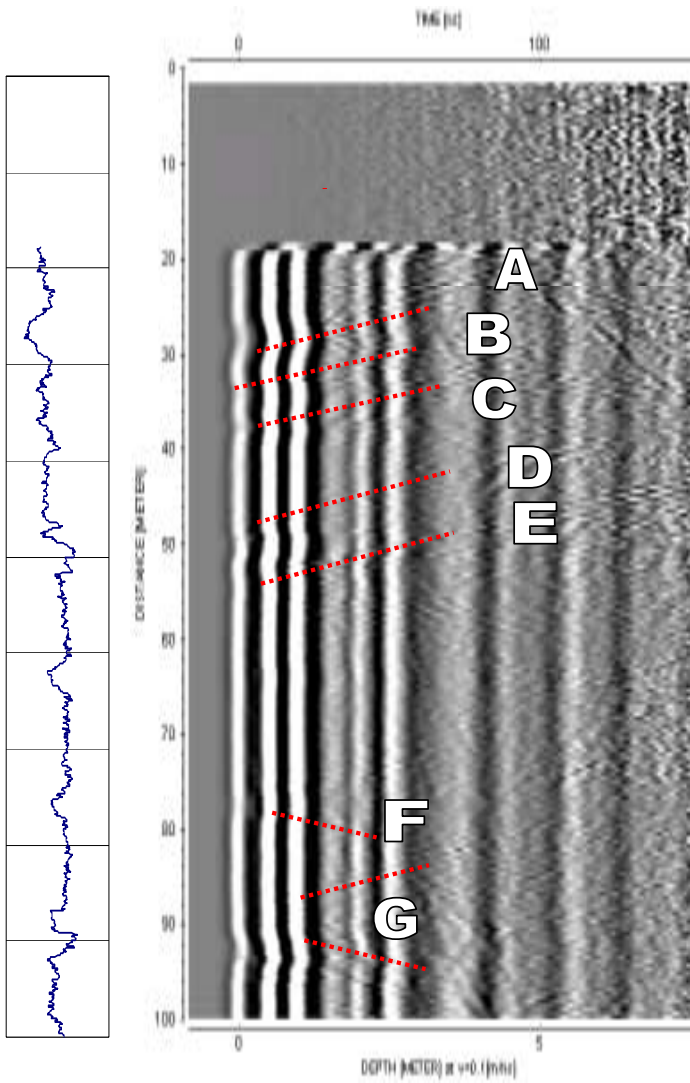

250 MHz

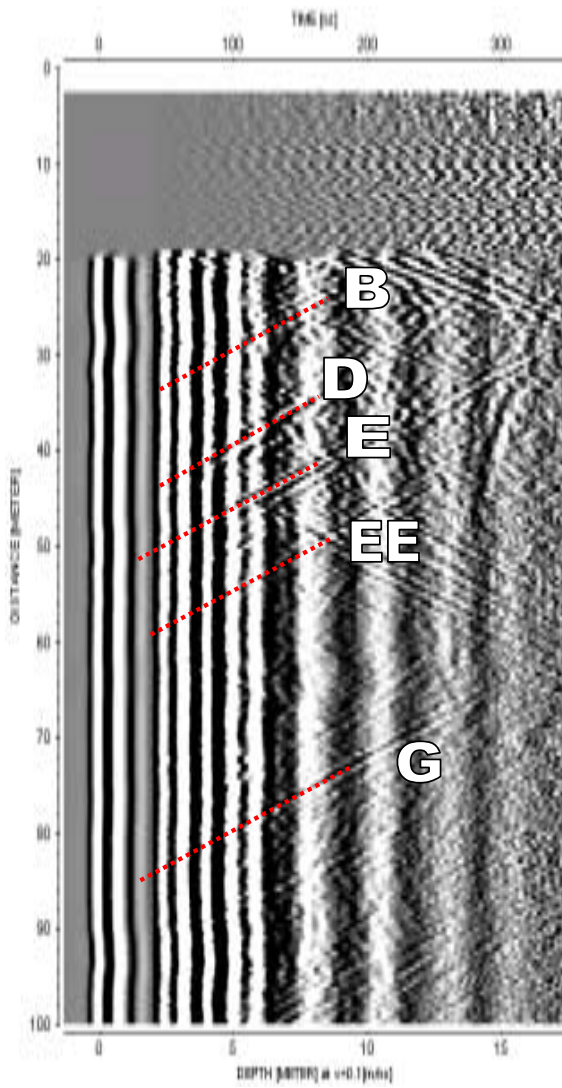

100 MHz

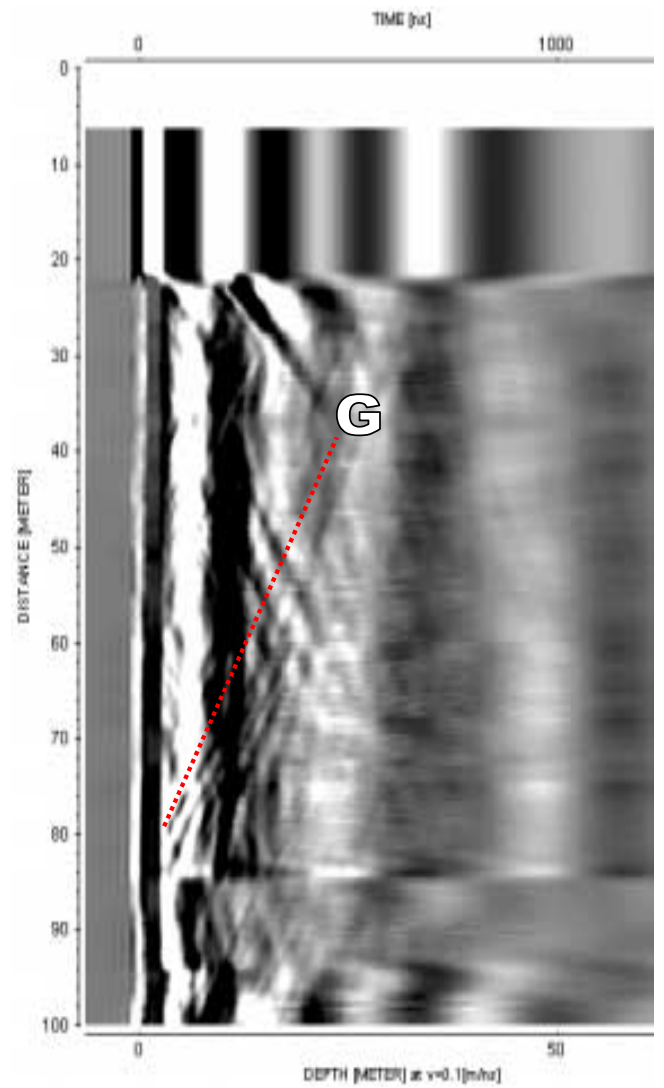

20 MHz



Forsmark HFM08

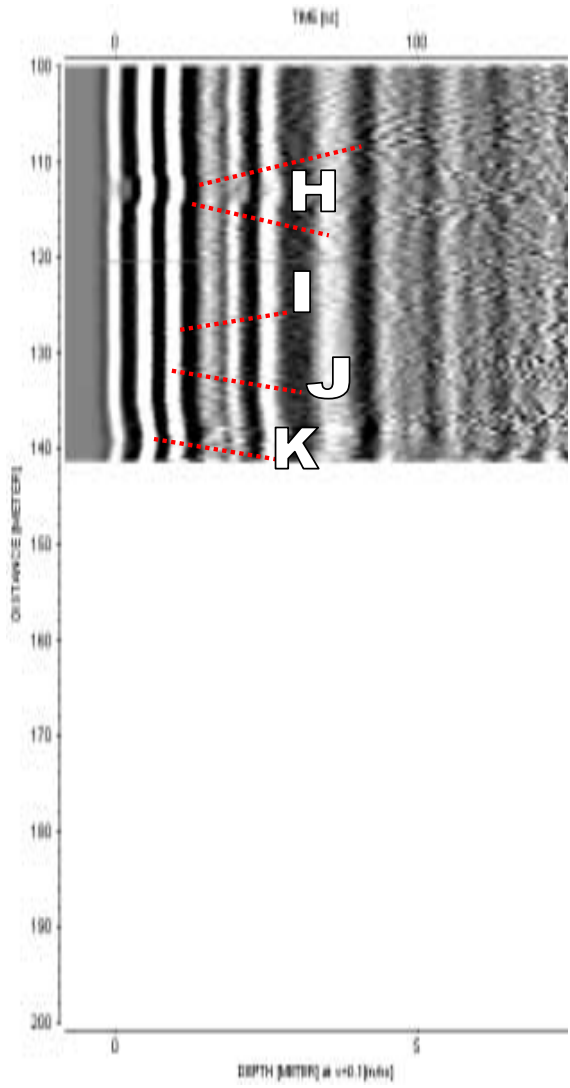

250 MHz

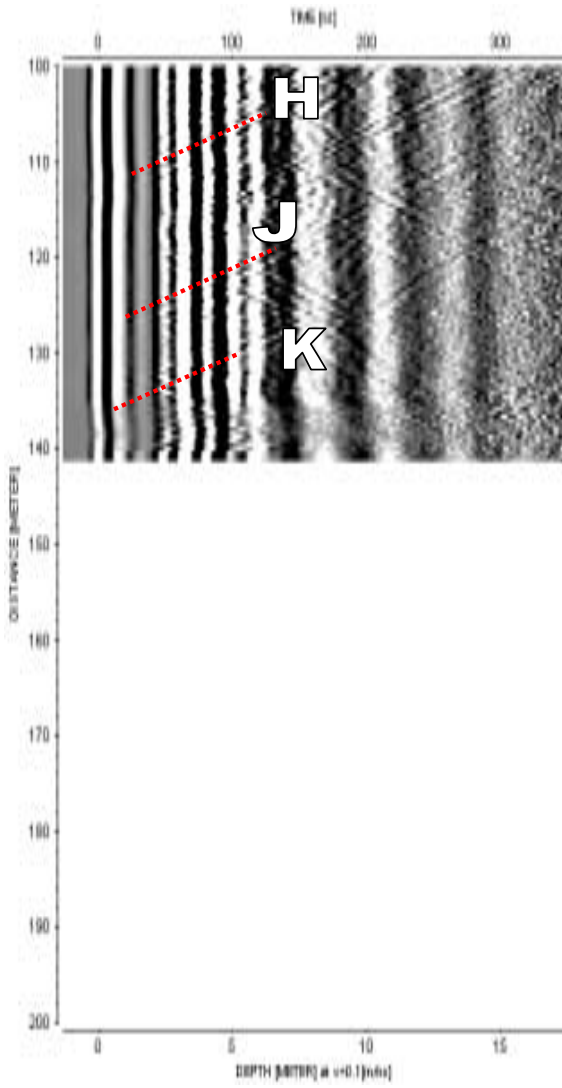

100 MHz

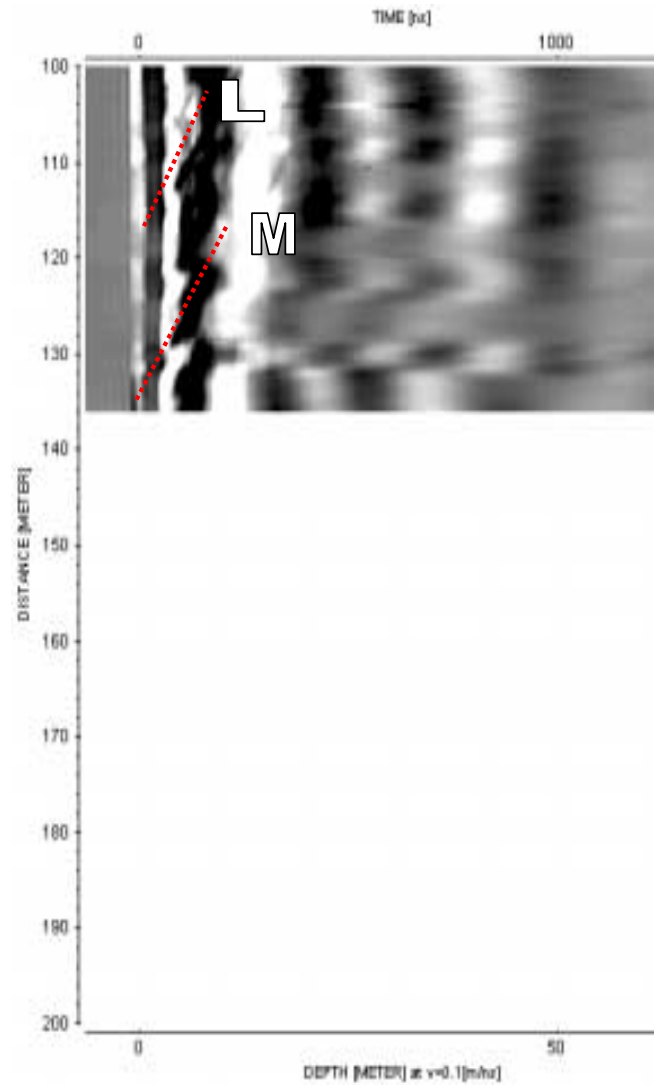

20 MHz